

POWER UP

TO **PUSH-BUTTON** PERFORMANCE



Furlex Electric



lla - Blue

edreg

Astroline

RODOLA PLUS



Furlex has been making life on board easier for decades. In fact, Furlex is the best-selling headsail furler in the world. Once you have experienced using a Furlex you will not want anything else up front. And now there is a new Furlex that will make life on board even easier. Lean back and enjoy Furlex Electric.

All the power you need

The new Furlex Electric is available as a complete kit or as an upgrade kit for an existing Furlex 200S or 300S series. The push-button performance of a Furlex Electric makes pulling on the furling line a thing of the past.

Reliable action

Furlex Electric is designed around a highly efficient 12V or 24V electric motor. Power is transmitted to a self-locking worm gear to rotate the luff extrusion at a max torque of 60Nm (200E) and 90Nm (300E) respectively. These high torque levels mean that you can always rely on being able to furl your foresail – even when the wind and sea are doing their worst. The motor uses only 30 amps at normal load and it takes 25-30 seconds to furl a genoa. Once the required sail area is set, the worm drive provides a mechanical lock.

In order to prevent accidental overloading, the system comes with a built-in circuit breaker. If you attempt to reef the sail without first releasing the sheet, the power is immediately switched off. This safety feature is automatically re-set a few seconds after the control switch is released. In the event of power failure, the sail is simple to reef manually. An emergency line-driver system is included as standard and can be used for both on-deck and through-deck installations. An emergency handle with ½" socket is available as an option.

Like all other Furlex models, Furlex Electric is equipped with Seldén's unique load distributor in the halyard swivel for low friction. Low friction means low power consumption and long service life.





On-deck or through-deck. The choice is yours

Furlex Electric is available for either on-deck or through-deck installations. The main advantage of a through-deck installation is better sailing performance as a result of maximised luff length. More space on the foredeck is an added bonus!



*Through-deck installation of a Furlex 200E.
The connection box is water-tight.*

Upgrade your manual Furlex

Push-button performance is an easy upgrade for anyone who already has a manual Furlex 200S or 300S series on their yacht. The furling line, drum and line guard assembly are simply replaced with a Furlex Electric motor unit. No sail conversion is required as the luff length of your existing sail is unaffected.



Manual Furlex 200S.



Remove line guard, line guide, rope and drum halves.



Ready to get powered up.



Slide on Furlex 200E from below and install the cables. Done!



Heavy-duty toggle to withstand torsional loads. An extension link is available to provide anchor clearance.

In case of power failure, Furlex Electric can be operated manually.



Manufactured from high-grade materials for rugged reliability and long service life.



Adjustment screws enable the Furlex housing to be aligned precisely.



Furlex Electric specifications

Type	Forestay diam. mm	L mm	H3 mm	HW mm	W2 mm	D2 diam. mm	H2 mm
200E	6	225	60	160	12	10	45
	7				14	12	
	8				14	14	
300E	8	260	80	210	14	14	65
	10				16	16	

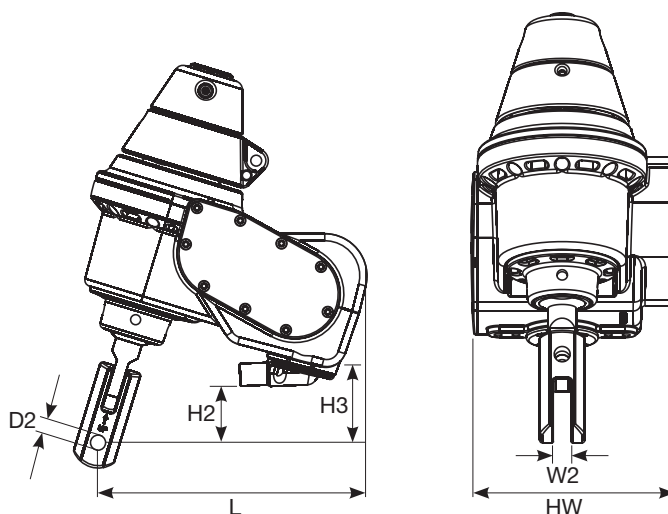

Type	Forestay diameter mm	Max. forestay length, m	Furlex Electric assemblies (excl. control pack)						Control pack* Art. No.	
			Standard version Art. No.		Incl. rigging screw Art. No.		TD version (through-deck) Art. No.		12V	24V
			12V	24V	12V	24V	12V	24V		
200E	6	10.6	031-021-11	N/A	031-021-21	N/A	031-021-31	N/A	532-448-01	N/A
	6	13.0	031-021-12	N/A	031-021-22	N/A	031-021-32	N/A		
	6	15.4	031-021-13	N/A	031-021-23	N/A	031-021-33	N/A		
	7	13.0	031-021-14	N/A	031-021-24	N/A	031-021-34	N/A		
	7	15.4	031-021-15	N/A	031-021-25	N/A	031-021-35	N/A		
	7	17.8	031-021-16	N/A	031-021-26	N/A	031-021-36	N/A		
	8	15.4	031-021-17	N/A	031-021-27	N/A	031-021-37	N/A		
	8	17.8	031-021-18	N/A	031-021-28	N/A	031-021-38	N/A		
300E	8	15.5	039-027-11	039-027-16	039-027-21	039-027-26	039-027-31	039-027-36	532-449-01	532-449-03
	8	17.9	039-027-12	039-027-17	039-027-22	039-027-27	039-027-32	039-027-37		
	10	15.5	039-027-13	039-027-18	039-027-23	039-027-28	039-027-33	039-027-38		
	10	17.9	039-027-14	039-027-19	039-027-24	039-027-29	039-027-34	039-027-39		
	10	20.3	039-027-15	039-027-20	039-027-25	039-027-30	039-027-35	039-027-40		

Cables & fuses included:

Furlex → connection box. Control box → switches. Control box → control panel.
Fuse for control circuit in control box.

Cables & fuses not included:

Connection box → control box. Control box → battery. Fuse for power supply.

* Includes deck gland, control box, connection box, instructions and switches.
Control pack is ordered separately, often prior to the delivery of the Furlex Electric assembly.

Type	Forestay diameter, mm	Retro-fit installation kit incl. control pack Art. No.	
		12V	24V
200E	6	539-620-11	N/A
	7	539-620-13	N/A
	8	539-620-15	N/A
300E	8	539-638-11	539-638-21
	10	539-638-13	539-638-23

Optional items	Art. No.
Remote control	532-510-01
Stainless steel panel for switches (100 x 56 x 3 mm)	540-462-01
Emergency handle (1/2" socket)	533-922
Ø 6/7 mm eye/fork extension link, L=90 mm	517-070-01
Ø 8/10 mm eye/fork extension link, L=130 mm	517-071-01

For further technical information, please see our instructions for installation, www.seldenmast.com.

DINGHIESKEELBOATSYACHTS

Seldén Mast AB, Sweden
Tel +46 (0)31 69 69 00
Fax +46 (0)31 29 71 37
e-mail info@seldenmast.com

Seldén Mast Limited, UK
Tel +44 (0)1329 50 40 00
Fax +44 (0)1329 50 40 49
e-mail info@seldenmast.co.uk

Seldén Mast Inc., USA
Tel +1 843-760-6278
Fax +1 843-760-1220
e-mail info@seldenus.com

Seldén Mast A/S, Denmark
Tel +45 39 18 44 00
Fax +45 39 27 17 00
e-mail info@seldenmast.dk

**Seldén Mid Europe B.V.,
Netherlands**
Tel +31 (0)111-698 120
Fax +31 (0)111-698 130
e-mail info@seldenmast.nl

Seldén Mast SAS, France
Tel +33 (0)251 362 110
Fax +33 (0)251 362 185
e-mail info@seldenmast.fr

www.seldenmast.com

The Seldén Group is the world's leading manufacturer of masts and rigging systems in carbon and aluminium for dinghies, keelboats and yachts.

The Group consists of Seldén Mast AB in Sweden, Seldén Mast A/S in Denmark, Seldén Mast Ltd in the UK, Seldén Mid Europe B.V. in the Netherlands, Seldén Mast SAS in France and Seldén Mast Inc. in the USA. Our well known brands are Seldén and Furlex. The worldwide success of Furlex has enabled us to build a network of over 750 authorised dealers covering the world's marine markets. So wherever you sail, you can be sure of fast access to our service, spare parts and know-how.